

The Cutting Edge of Tinware's Past

Tin Snips

The Research Library

Instruction Manual For Sheet-Metal Workers

by R. W. Selvidge,

Peoria, Illinois: The Manual Arts Press, pp 48-49, 61-65

Edited by P. M. Cunningham

Burring Edges with a Machine

Directions:

Forming a Small Right Angle Burr at the End of a Cylinder. Fig 20.

1. Set the gage on the left side of the machine to the width of the burr to be formed. Hold the metal object in a horizontal position with its edge resin against the gage. Turn the crank at the top of the machine to set the upper burring wheel lightly on the metal. Turn the handle of the machine until a small depression is made in the metal all around the object.

Continue to turn the handle and at the same time raise the object until a right angle burr is formed. Do not set the burring wheel down on the metal too tight or the edge will crimp and curl.

Burring a Circular Disc to Fit Over the End of a Cylinder. Fig 21.

2. The metal disc should be large enough so that after the burr is formed on it, it will slip over the burred edge of the cylinder.

3. Fold crosswise a piece of metal 1 1/2 inches wide and 3 inches long so that the angle will be about 30 degrees, and hold it in the crotch between the thumb and

•continued on page 2

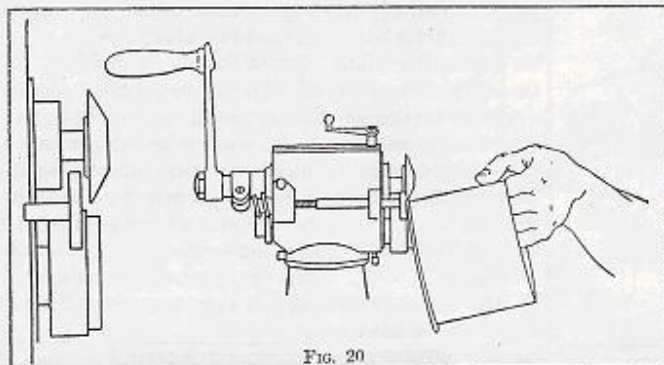

FIG. 20

Reflections in the Plate In This Issue

The primary article in this issue was contributed by Leo Winkler in response to Jeff Goris's inquiry last issue on the purpose of the protrusion on burring machines. Leo sent the pages to show that the protrusion was designed as a hand rest. I decided to reprint several pages of what was sent because over the years several readers have requested basic machinery guidelines. During the recent open house at my shop it became apparent that each of us has developed our own techniques for using our machinery. If anyone has any personal tricks to add to what is being reprinted in this issue please send them to Tin Snips to be published in a future issue.

The article on the passing of Dale The Tinker has been expanded to this issue because a few submissions arrived after the last publishing deadline. I believe the thoughts of the people express a deep loss for Dale and it is important that they be published. This puts a positive end to the passing of the man.

Other than that, this issue starts Tin Snips out on its third year under my editorship. I hope it continues to be well received.

-P. M. Cunningham

Tin Snips

c/o P. M. Cunningham
402 East Main St.
Madison, IN 47250
(812) 273-4193 and fax

Subscriptions, submissions & back issues:

Subscriptions are \$15 per year for six bimonthly issues. Back issues are \$2.50 each. Send checks or money orders to the address above.

This newsletter exists for *you*, so do not forget to send in your submissions to the same address.

March/April 1996

Volume 6 Number 2

Instruction Manual: continued from page 1

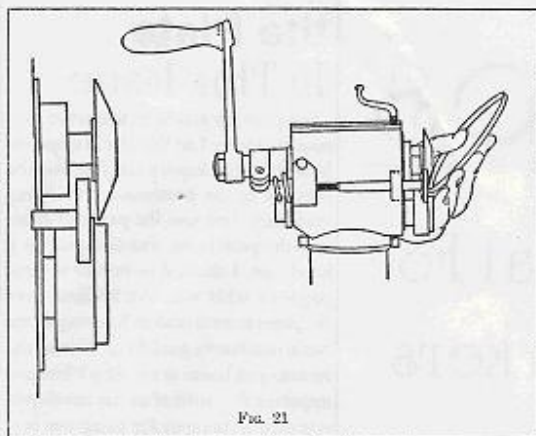

FIG. 21

first finger of the left hand.

4. With the metal disc resting in a horizontal position on the lower roll and its edge touching the gage, bring down the upper roll until the disc is held firmly between the two rolls. Allow the disc to rest on your finger tips and bear against its upper surface with your thumb. Rest the palm of your hand against the frame of the machine, turn the handle and allow the disc to pass freely thru your hand, being careful to keep the folded strip of metal between your hand and the edge of the revolving disc. While turning the machine, raise the disc gradually until a burr is turned on its edge, slightly beyond a right angle. Turn the machine rapidly to avoid buckling the metal.

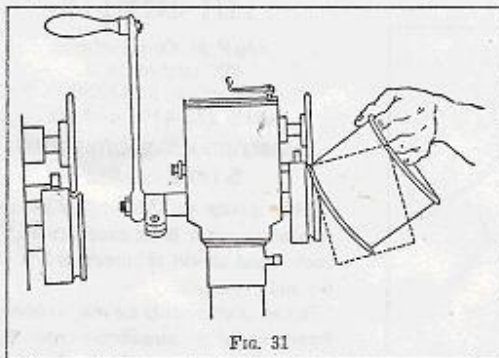

FIG. 31

Turning Edges with a Machine

Directions:
Turning Edges for Seaming Cylindrical Articles. Fig 31.

1. Set the gage to the width of the turned edge desired and lock it in place with a set screw.

2. Rest the cylinder in a horizontal position on the

lower roll with its end pressed firmly against the gage. Turn the crank screw on top of the machine to lower the upper roll until it makes a slight depression in the metal. Turn the handle of the machine to revolve the cylinder between the rolls and at the same time raise the cylinder with the left hand until the edge is turned to a right angle.

Turning an Edge on a Circular Metal Disc. Fig 32.

3. Hold the metal disc

in the palm of your hand, place it in the machine in a horizontal position firmly against the gage, bring down the upper roll and turn the edge as directed for a cylinder. Turn the machine slowly and use care to keep the edge of the metal disc against the gage.

Turning an Edge for Wiring.

4. Use turning rolls slightly thicker than the diameter of the wire to

be used. Set the gage to 2 1/2 times the diameter of the wire from the inside edge of the upper turning roll. Place the metal between the rolls and turn an edge as directed for a cylinder, then lower the upper roll as far as it will go and continue the turning operation until the edge is turned well beyond a right angle. 5. When a turning machine is used to form a flange, finish the flange by holding it on a square stake and hammering it smooth.

Turning Elbow Edges.

6. Each seam requires the turning of a single and double edge. Set the gage to the width of the single edge and turn the edge of one piece until the flange which is formed will touch all around when laid on a flat surface. Set the gage to twice the width of single edge and turn the edge of the other piece the same as the single

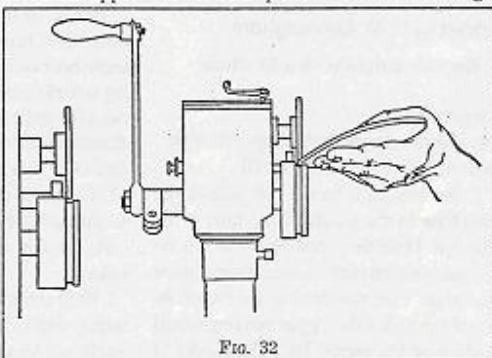

FIG. 32

edge. Then set the gage to the width of the single edge and turn half of the wide edge back until it forms a right angle with the part formed first.

Special Rolls for Elbow Edging.

7. Place the special elbow edging rolls on the turning machine and set the gage to the width of the edge desired. Hold the elbow sections between the rolls in a horizontal position. Bring down the upper roll until it touches the metal, then turn the handle of the machine' at the same time gradually lower the upper roll until the metal is pressed to fit the shape of the rolls.

•continued on page 3

Snippets

News from you and other scraps

Editor's note

Last issue I was informed this article was published without its drawing. For that reason, it is being reprinted with the drawings, so it will hopefully make more sense to some.

Walt Fleming
Ballston Lake, NY

POOR MANS BARFOLD or have you ever wanted to turn an edge on a piece of tinplate and you couldn't use your barfold due to the geometric shape of the piece. (i.e. an overhang in the design) or it was too long for your standard 21" opening?

Using a short Hand Folder works but the end result is often less than perfect. Pick up a roofing folder (see p. 125 of The Peck, Stow & Wilcox Co. Catalog of 1900) for very little money (usually less than \$25.00). It's a wooden tool with

steel edges for folding. Be sure to move the two hinges out to the very edge of the tool, since they will just be in the way during use. The depth of the fold is set and not adjustable as in a barfold but don't let that stop you. You can easily and very quickly make a scribe with a guide to follow the edge of the piece you want to fold and use this mark to set the piece to the proper depth in the roofing folder.

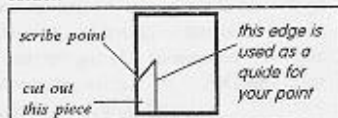

Note: This scribe idea came to me the minute Bill McMillen told me how to make one!

Dale the Tinker uses a wing divider, set to various widths, to accomplish the same

New Subscribers

•Donald Carrick

Zoar, OH

•Carl Giordano
Giordano Crafts

Wadsworth, OH

•Robert Allen Ragland, Jr.

Murfreesboro, TN

•Michael Runyon
Sauder Village

Archbold, OH

thing. It works especially well when one leg of the divider is a bit shorter than the other.

After this article is published the demand for roofing folders will go up along with the price. Better get yours early!

Instruction Manual: continued from page 2

Wiring Edges

Directions:

1. Wired edges for cylindrical shaped objects should be completed while the metal sheet is flat.
2. Insert the wire in the edge prepared by the turning machine or the bar folder and secure the wire at several points by bending the metal over it with a hammer.
3. Place over the lower roll of the wiring machine a section of the edge in which the metal has been bent around the wire and turn the crank screw on top of the machine to bring down the upper roll.
4. Set the gage so that the wired edge fits snugly between the gage and the edge of the upper roll, then turn the crank screw back about two turns to slightly raise the upper roll.
5. Turn the handle of the machine to

draw the entire edge between the rolls. Lower the upper roll and pass the edge between the rolls again, until the metal is pressed firmly around the wire; and at the same time, raise the object being wired, in order to bend the extreme edge of the metal under the wire. Fig. 33.

Wiring Edges of Objects with Straight Sides.

6. Fold the edges on a folder or brake while the metal sheet is flat.
7. Bend the sheet to the form or shape desired and secure the joints or seams.

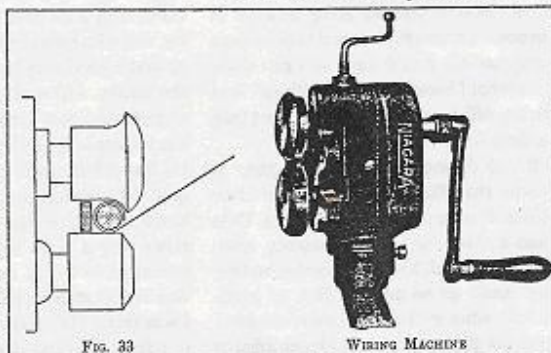

March/April 1996 • TIN SNIPS